

THIS DRAWING IS UNPUBLISHED. RELEASED FOR PUBLICATION 20
 © COPYRIGHT 20 BY TYCO ELECTRONICS CORPORATION. ALL INTERNATIONAL RIGHTS RESERVED.

LOC		DIST		REVISIONS			
P	LTR	DESCRIPTION	DATE	DWN	APVD		
	F	REVISED	26 JAN 2011	T.S	N.Y		

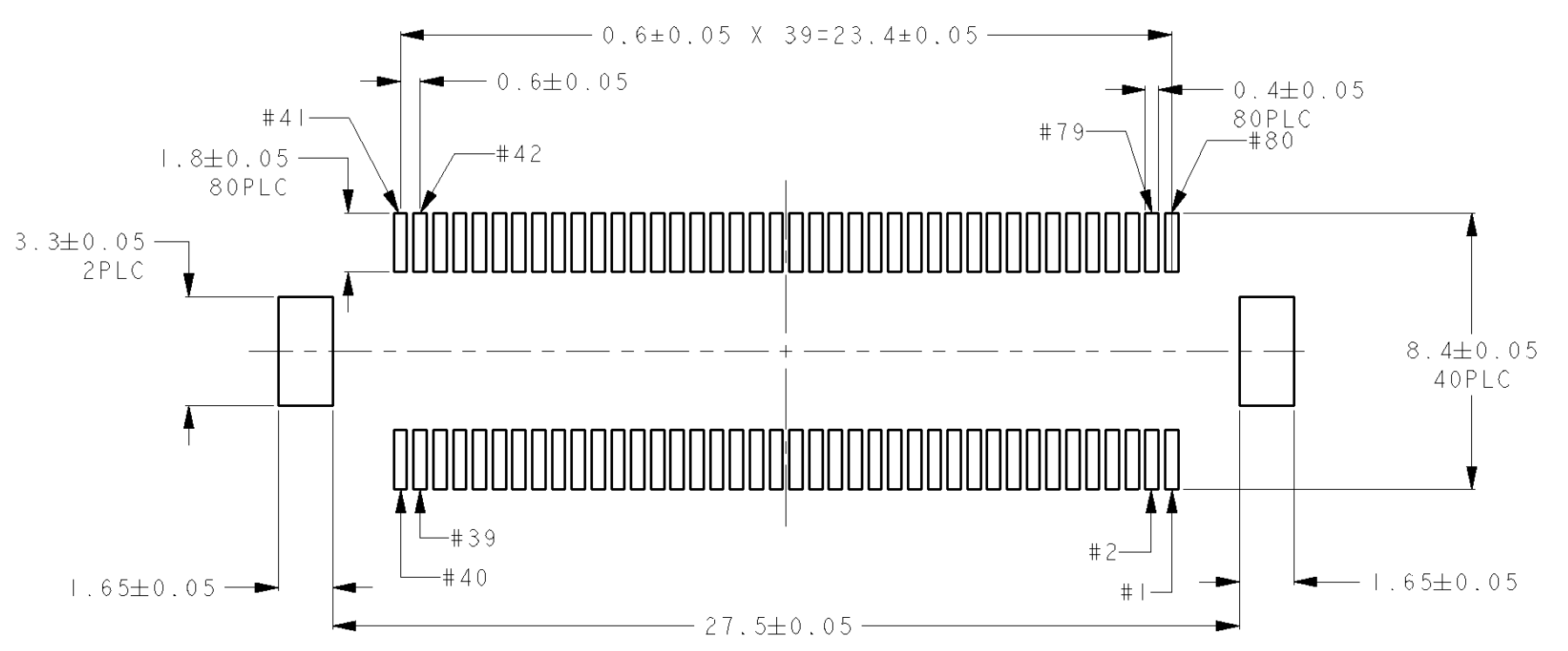
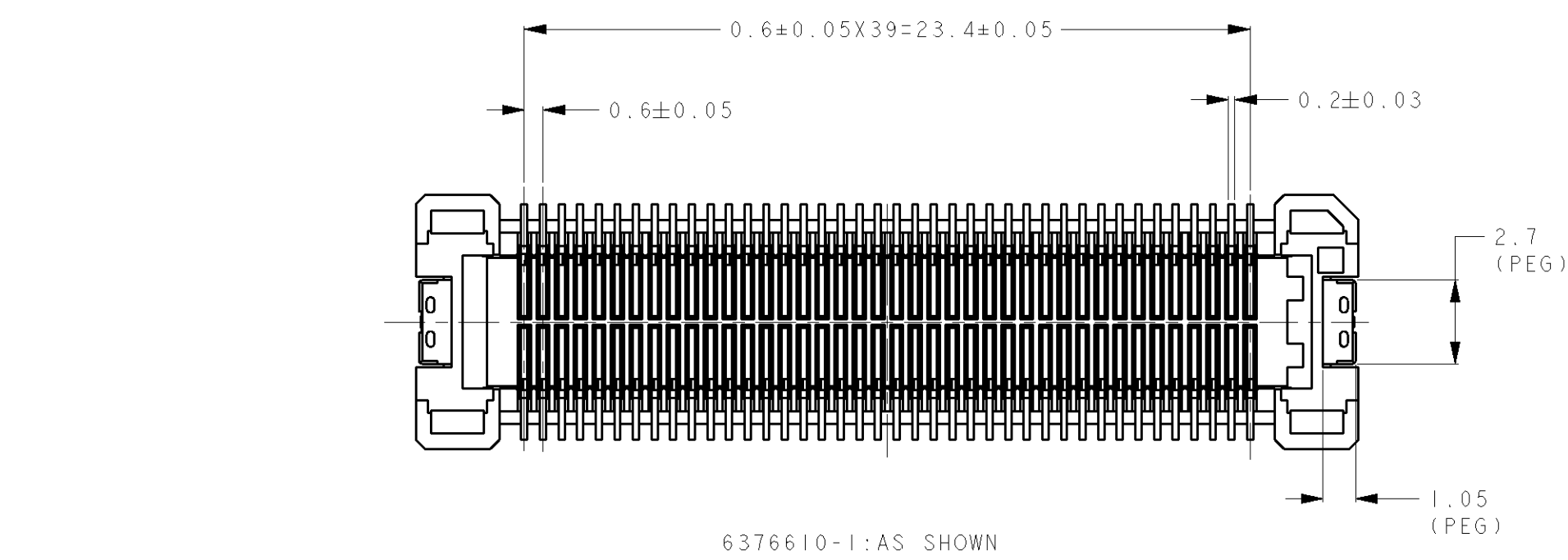
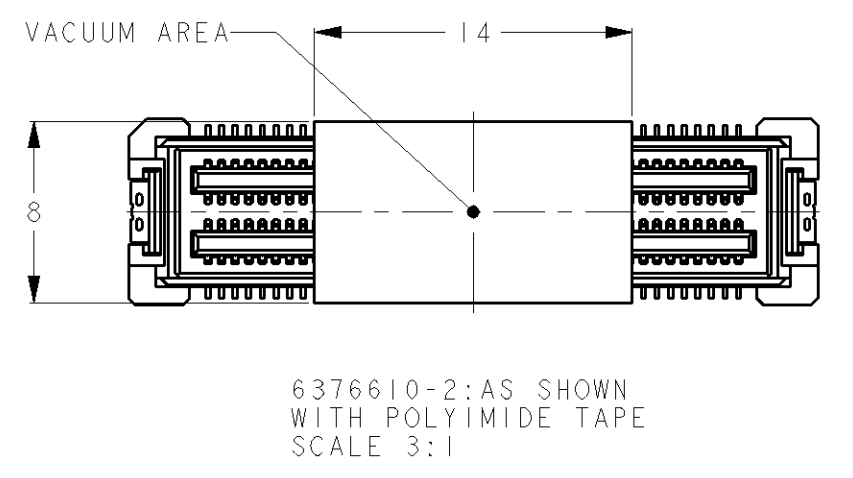
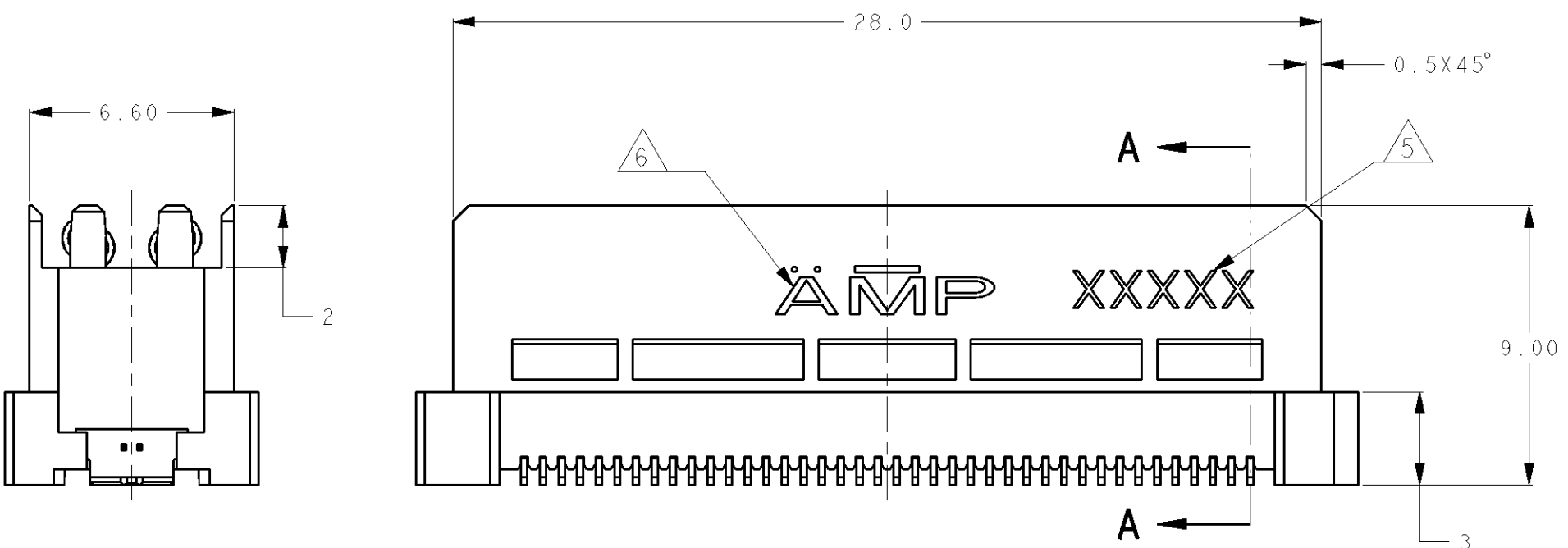
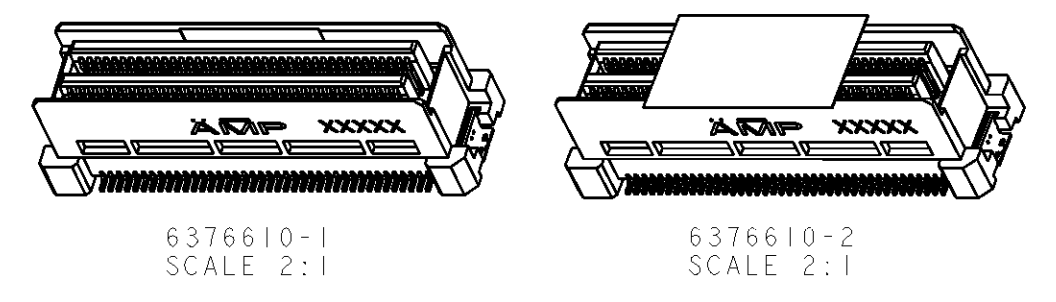
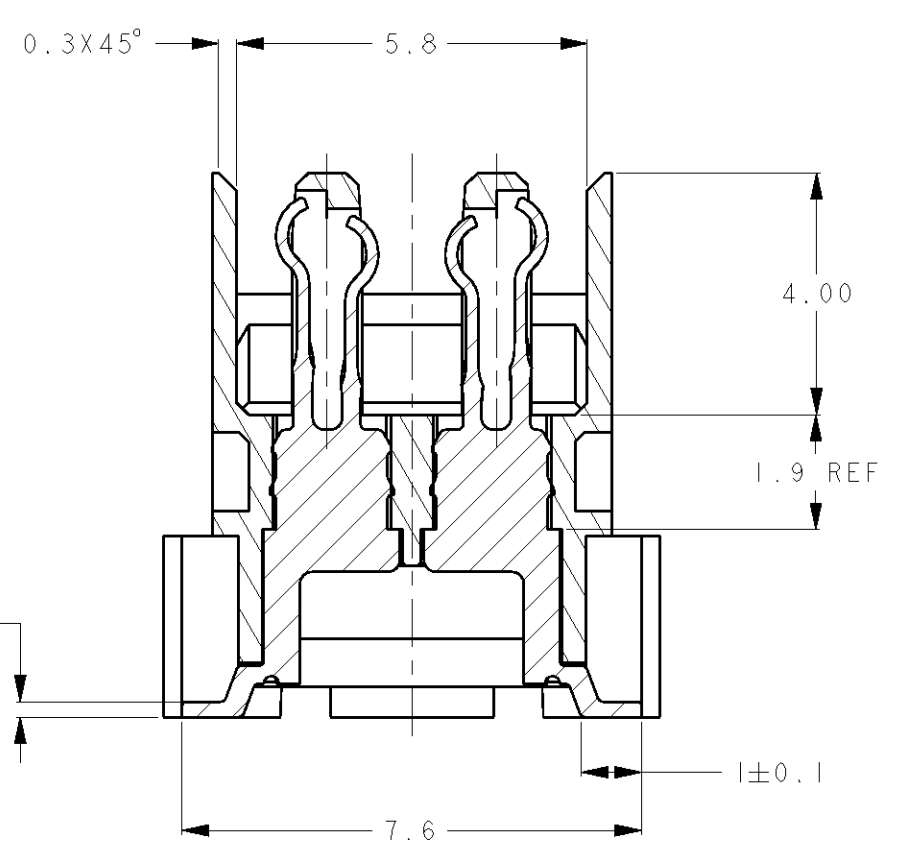
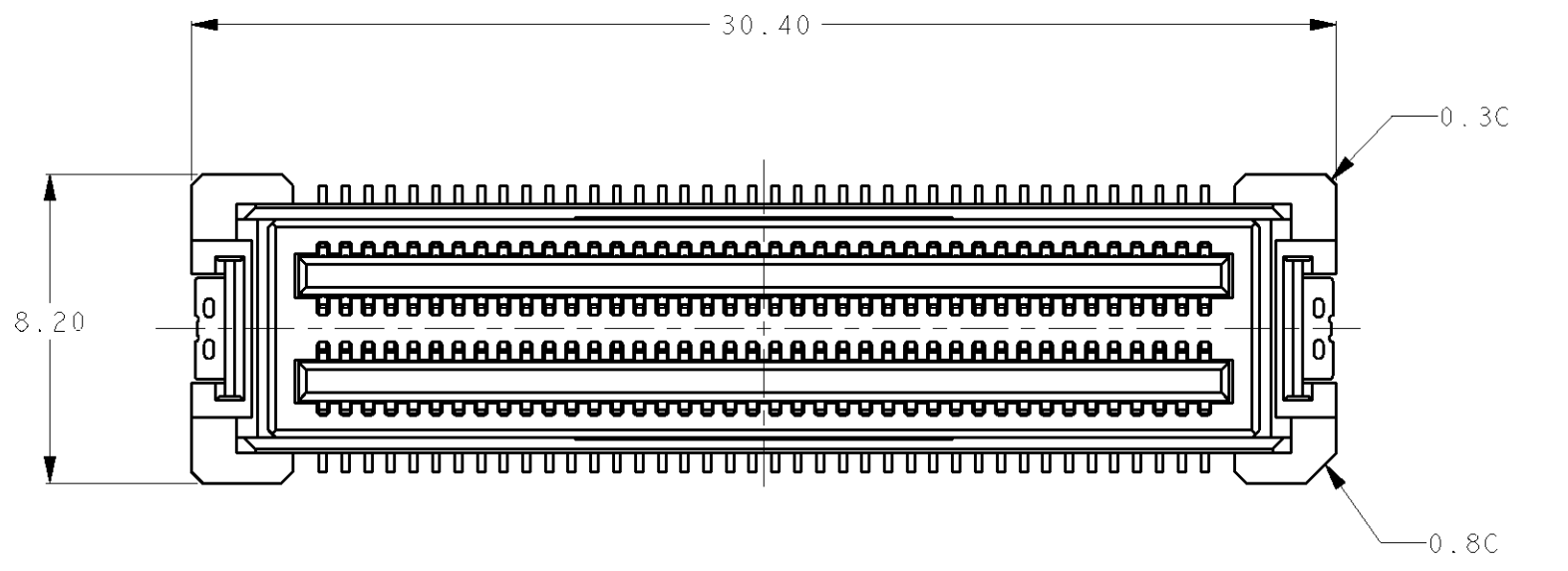

推奨基板取付寸法
 RECOMMENDED PCB LAYOUT

WITH POLYIMIDE TAPE	6376610-2
W/O POLYIMIDE TAPE	6376610-1
DESCRIPTION	PART NO

1 MATERIAL : HOUSING; LCP
 : CONTACT; COPPER ALLOY

2 FINISH : UNDER Ni PL. 0.8μmMIN
 CONTACT AREA: Au PL. 0.3μmMIN
 SOLDERING AREA: Au FLASH

3. COPLANARITY 0.1MAX.

4. SHOULD BE PUT 45 CONNECTORS IN HARD TRAY. (SEE SHEET 2)

5 DATE CODE IS MARKED TO CHINA PRODUCTION PRODUCT.
 THE FACE SIDE AND BACK SIDE IS NOT ASKED.

6 AMP : MADE IN JAPAN
 AMP : MADE IN CHINA

1 材料: ハウジング : 液晶ポリマー
 : コンタクト : 銅合金

2 仕上げ : 全面ニッケル下地 0.8μmMIN
 接点部 金メッキ 0.3μmMIN
 半田付部 金フラッシュ

3. コプラナリティー 0.1MAX

4. 梱包形態は、ハードトレイに45個入りとする。(シート2参照)

5 中国生産品に関しては、このエリアにアートコードが印字される。
 ハウジングの表裏は問わない。

6 AMP : 日本生産品
 AMP : 中国生産品

THIS DRAWING IS A CONTROLLED DOCUMENT FOR TYCO ELECTRONICS CORPORATION IT IS SUBJECT TO CHANGE AND THE CONTROLLING ENGINEERING ORGANIZATION SHOULD BE CONTACTED FOR THE LATEST REVISION		DWN K. Sakai 23 JAN 2006	Tyco Electronics Corporation Kawasaki, Japan
DIMENSIONS: 単位: 概 mm		CHK E. Takemasa 23 JAN 2006	
TOLERANCES UNLESS OTHERWISE SPECIFIED: 一般公差 0 PLC ±0.3 1 PLC ±0.25 2 PLC ±0.2 3 PLC ± 4 PLC ± ANGLES ±3°		APVD M. Kimura 23 JAN 2006	NAME HDR ASSEMBLY 9mm HEIGHT 0.6mm PITCH 80P MICRO STACK CONNECTOR
MATERIAL 材料 SEE NOTE		PRODUCT SPEC 108-5724	SIZE A2p0779
FINISH 仕上 SEE NOTE		APPLICATION SPEC 取付適用規格	DRAWING NO C=6376610
WEIGHT 2.1g		CAGE CODE	RESTRICTED TO -
CUSTOMER DRAWING		SCALE 5:1	SHEET 1 OF 2 REV F

THIS DRAWING IS UNPUBLISHED. RELEASED FOR PUBLICATION 20
 © COPYRIGHT 20 BY TYCO ELECTRONICS CORPORATION. ALL INTERNATIONAL RIGHTS RESERVED.

LOC	DIST	REVISIONS					
J	-	P	LTR	DESCRIPTION	DATE	DWN	APVD
		-		SEE SHEET 1	-	-	-

- I: AS SHOWN
 - I: 本図

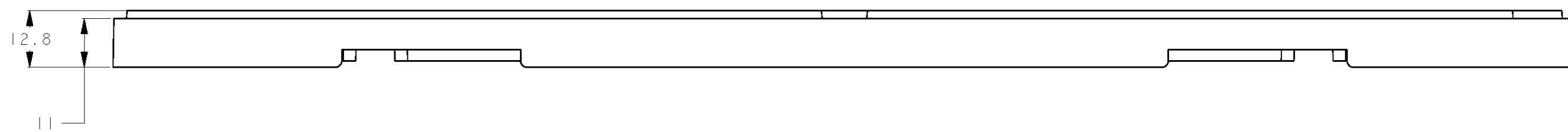
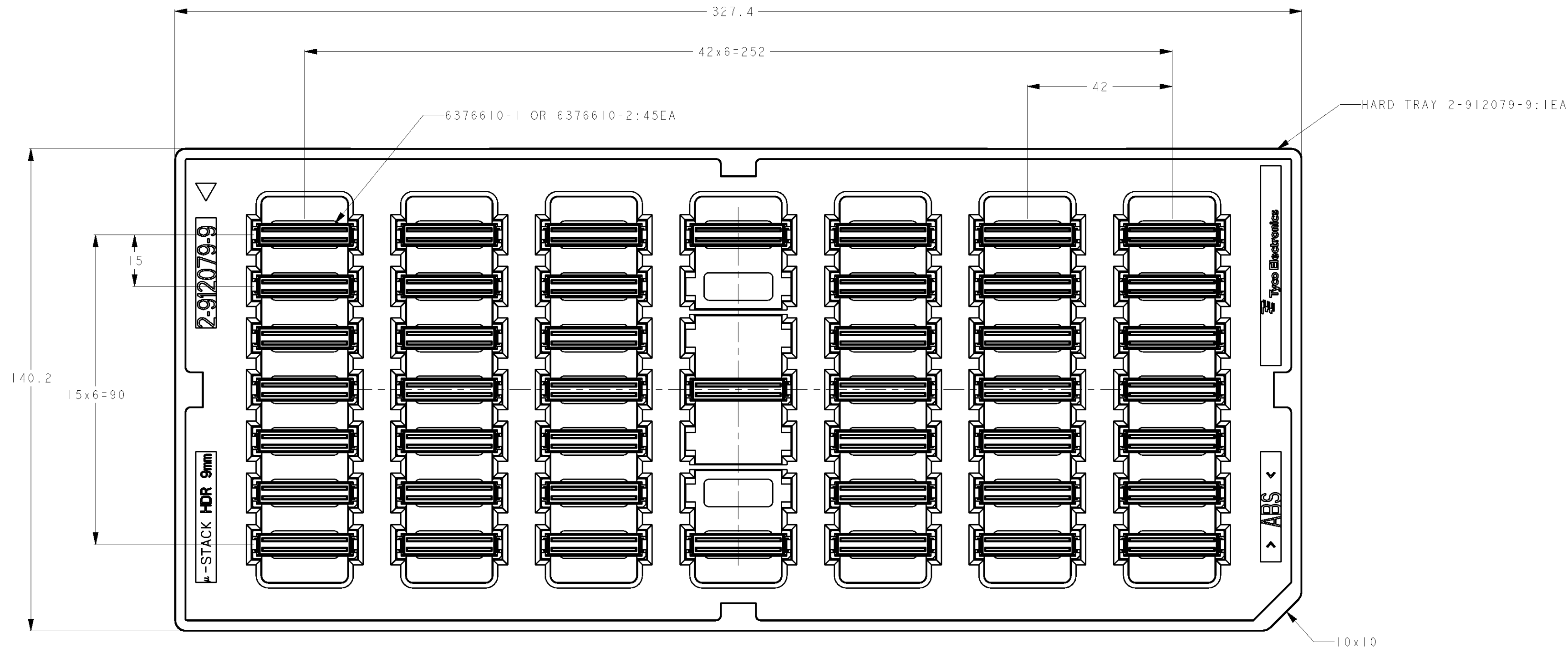

HARD TRAY ASSEMBLY SPEC

<small>THIS DRAWING IS A CONTROLLED DOCUMENT FOR TYCO ELECTRONICS CORPORATION IT IS SUBJECT TO CHANGE AND THE CONTROLLING ENGINEERING ORGANIZATION SHOULD BE CONTACTED FOR THE LATEST REVISION</small>		DWN K. Sakai 23JAN2006 CHK E. Takemasa 23JAN2006 APVD M. Kimura 23JAN2006	Tyco Electronics Tyco Electronics Corporation Kawasaki, Japan	
DIMENSIONS: 単位: 概 mm	TOLERANCES UNLESS OTHERWISE SPECIFIED: 一般公差 ± 1 0-PLC ± 0.3 1-PLC ± 0.25 2-PLC ± 0.2 3-PLC ± 0.2 4-PLC ± 0.2 ANGLES ± 3° FINISH 仕上	PRODUCT SPEC 108-5724 APPLICATION SPEC 取付適用規格	NAME HDR ASSEMBLY 9mm HEIGHT 0.6mm PITCH 80P MICRO STACK CONNECTOR	
MATERIAL 材料	WEIGHT 2.1g	SIZE A20779	CAGE CODE C-6376610	RESTRICTED TO -
CUSTOMER DRAWING		SCALE 3:1	SHEET 2 OF 2	REV F